



# Historic Bridge Management Plan for the Bobtown Bridge

**Recall Number: 200868**

**Structure Number: P5529283904221**

**Parish: Terrebonne**

**Route: Parish Road No. 283/Bobtown Bridge Road**

**Crossing Description: Grand Caillou Bayou**



Prepared for

**Louisiana Department of  
Transportation and  
Development**

Prepared by

**Mead  
& Hunt**

[www.meadhunt.com](http://www.meadhunt.com)

August 2016

**THIS PAGE INTENTIONALLY LEFT BLANK**

## Table of Contents

	Page
<b>Executive Summary .....</b>	<b>1</b>
<b>1. Introduction .....</b>	<b>3</b>
<b>2. Location Map .....</b>	<b>5</b>
<b>3. Historic Data .....</b>	<b>7</b>
A. Identifying information .....	7
B. Description of bridge .....	7
C. History and significance .....	8
D. Character-defining features .....	10
<b>4. Engineering Data.....</b>	<b>15</b>
A. Existing conditions .....	15
(1) Structural observations .....	15
(2) Non-structural observations .....	16
(3) Serviceability observations.....	16
B. Sources of information.....	17
<b>5. Recommendations .....</b>	<b>25</b>
A. Preventative maintenance .....	25
B. Rehabilitation .....	26
C. Identification of any anticipated design exceptions .....	27

### Appendices

- A Historic Inventory Form
- B Select Plan Sheets

**THIS PAGE INTENTIONALLY LEFT BLANK**

## Executive Summary

The Bobtown Bridge (Recall No. 200868) is located in Terrebonne Parish, Louisiana, and is owned by Terrebonne Parish. Constructed in 1960, the bridge was determined eligible for the National Register of Historic Places (National Register) in 2013. It is significant as a distinctive example of a cable-stayed swing bridge featuring a truss swing span, center-bearing turning mechanism, and tower structure with cables that support the bridge in the open position.

The bridge carries a single lane of traffic on Parish Road No. 283/Bobtown Bridge Road across Bayou Grand Caillou south of the city of Houma in Terrebonne Parish. At 158 feet long it contains the main movable truss span as well as two approach spans to the west. The main span is a 128-foot-long, cable-stayed swing truss span that rests on a center-bearing turning mechanism supported by a timber pivot pier. Its movement is guided with a rope and pulley system driven by a motorized winch in the operator's house. Two 15-foot approach spans to the west of the swing span are made of steel I-beams and supported on timber piles. A timber fender system provides a 49-foot navigation channel through the bridge. This bridge is classified as a complex structure because it contains one swing span unit.

The Bobtown Bridge is in fair condition overall and appears to adequately serve its purpose of carrying vehicular traffic and occasional pedestrian traffic, subject to the weight posting of 10 tons. There are no major structural deficiencies with this bridge, but there are several minor deficiencies. With proper maintenance and rehabilitation, the bridge can continue to serve in its present capacity for 20 years or longer.

Any work on the bridge should proceed according to recommendations in this Historic Bridge Management Plan (Plan), which adhere to the *Secretary of the Interior's Standards for the Treatment of Historic Properties* (Secretary's Standards), the *Management Plan for Historic Bridges Statewide* (Statewide Historic Bridge Plan), and the *Programmatic Agreement among the Federal Highway Administration, the Louisiana Department of Transportation And Development, the Advisory Council on Historic Preservation, and the Louisiana State Historic Preservation Officer Regarding Management of Historic Bridges in Louisiana* (PA).

**THIS PAGE INTENTIONALLY LEFT BLANK**

## 1. Introduction

This Plan, used in conjunction with the Statewide Historic Bridge Plan, provides guidance on the approach to preservation activities for the Bobtown Bridge (Recall No. 200868), identified as a Preservation Priority Bridge. Completion of individual management plans for Preservation Priority Bridges and the Statewide Historic Bridge Plan fulfills terms of the PA, which was executed on September 21, 2015.

The PA provides the basis and procedures for the management of historic bridges in Louisiana and outlines the procedures for the treatment of historic bridges, including Preservation Priority Bridges. In accordance with the PA, an owner seeking state or federal funding for Preservation Priority Bridges will be required by the Louisiana Department of Transportation and Development (LADOTD), in cooperation with the Louisiana State Historic Preservation Office (LASHPO) and the Federal Highway Administration (FHWA), to follow the procedures outlined in this Plan and the Statewide Historic Bridge Plan.

The Statewide Historic Bridge Plan outlines the overall approach to bridge preservation through a discussion of the collaboration of the historian and engineer, guidance on assessing preservation needs, and resources and technical guidance on maintenance and rehabilitation activities that are broadly applicable to historic bridges. A glossary of common engineering and historical terms is included in the Statewide Historic Bridge Plan.

This Plan for the Bobtown Bridge compiles and summarizes the specific historic and engineering information for this Preservation Priority Bridge. It documents the existing use and condition of the bridge, along with assessments of the preservation needs, including cost estimates. Preservation can be accomplished in two manners: preventative maintenance and rehabilitation. Maintenance includes cyclical or condition-based activities that, along with regular structural inspections, are directed toward continued structure serviceability. Rehabilitation activities are near- or long-term steps that need to be taken to preserve and in some cases restore a bridge's structural condition and serviceability. In assessing preservation activities for each Preservation Priority Bridge, a design life of 20 years was considered, which is consistent with the duration of the PA. This Plan provides the bridge owner, and other interested parties, with detailed information related to the historic nature of the bridge and the necessary background to make an informed planning decision. Recommendations within this Plan should be reviewed in 10 years following completion of the Plan to identify any needed updates or revisions.

Existing bridge data sources typically available for Louisiana bridges were gathered for this Plan, and field investigation confirmed general structural condition and character-defining features of the subject bridge. These sources include:

- The current LADOTD Bridge Inspection Report, and any other similar inspection reports
- Original bridge construction plans, any rehabilitation plans, and record as-built plans, as available
- Existing historical and documentary material related to the historic bridges

Recommendations within this Plan are consistent with the Secretary's Standards. The Secretary's Standards are basic principles created to help preserve the distinct character of a historic property and its site, while allowing for reasonable change to meet new engineering standards and codes. The Secretary's Standards recommend repairing, rather than replacing, deteriorated features whenever possible. A version of the Secretary's Standards that is specific to historic bridges is included in the Statewide Historic Bridge Plan. Following these standards is a requirement of the PA.

A bridge historian and bridge engineer from Mead & Hunt, Inc. (Mead & Hunt) jointly prepared this Plan under contract to the LADOTD. The LADOTD, FHWA, and LASHPO reviewed and provided input into the final Plan.



## 2. Location Map

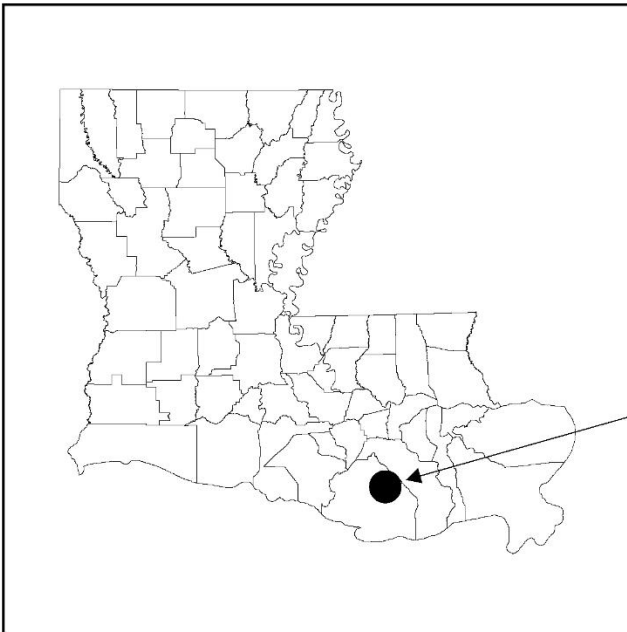
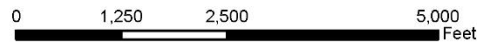

**PROJECT LOCATION**  
Bridge Number: 200868  
Structure Number: P5529283904221  
Terrebonne Parish  
Route: Parish Road No. 283/Bobtown Bridge Road  
Crossing Description: Grand Caillou Bayou

**THIS PAGE INTENTIONALLY LEFT BLANK**

### 3. Historic Data

#### A. Identifying information

**Structure Number:** P5529283904221

**Recall Number:** 200868

**LASHPO Number:** 55-01180

**Bridge Name:** Bobtown Bridge

**Date of Construction:** 1960; rehabilitated in 2001

**Main Span Type:** Cable-stayed Swing Span

**Contractor:** Unknown

**Designer/Engineer:** Unknown

#### B. Description of bridge

The Bobtown Bridge carries a single lane of traffic on Parish Road No. 283/Bobtown Bridge Road across Bayou Grand Caillou south of the city of Houma in Terrebonne Parish. The 158-foot bridge consists of a main cable-stayed swing span with steel approach spans to the west. It has a posted weight limit of 10 tons (10T), and average daily traffic (ADT) across the bridge is about 400 vehicles. The crossing was built in 1960 and rehabilitated in 2001; it retains nearly all elements of its original construction. This bridge is classified as a complex structure because it contains one swing span unit. It is also classified as fracture critical because failure of one truss could lead to the collapse of the bridge.

The main span of the bridge is a 128-foot-long cable-stayed, truss swing span supported by a central pivot pier and vertical tower. The swing span is comprised of two connected steel truss sections and a steel central tower. The length of each truss section is approximately 64 feet as measured from the center of the tower. The truss top and bottom chords and vertical members are I-shaped steel sections with welded connections. The center tower is also comprised of I-shaped steel members with welded connections. Three round steel rods support each truss span section from the center tower; there are a total of 12 rods. The bridge was rehabilitated in 2001 when a new horizontal top chord steel member was added to connect the two truss sections on either side of the center tower. These new horizontal members consist of two C-shaped steel members with the flanges facing each other. These horizontal members are welded to the original trusses with steel connection plates. The floor system consists of seven I-shaped steel beams supported on I-shaped steel floorbeams. The ends of the floorbeams are supported at the lower connections of the round steel rods.

The swing span is supported on a metal roller and track system that rests on a central pivot pier composed of timber caps and walers. The central pivot pier is supported on 14-inch-diameter treated timber pilings. The span is operated by a rope and pulley system that is mounted to a semi-circular timber platform at the northeast corner of the bridge, beneath its turning radius. A motorized winch in the operator's house is used to wind the rope to open the bridge.

There are two approach spans to the west of the main swing span, each approximately 15 feet long. They consist of seven I-shaped steel beams and are supported on 12-inch square treated timber caps, which are supported on 12-inch-diameter treated timber piles. The timber piles are jacketed and spliced with metal sleeves, which extend approximately down to the water line. There are no approach spans on the east side of the bridge; that end of the swing span is supported by the east abutment.

On the bridge deck the clear roadway width is 13 feet, 8 inches, which accommodates one lane of traffic with no curb or sidewalks. Traffic is controlled with signal lights and traffic gates at each end of the bridge. The deck on the swing span and approach spans consists of 3-inch-thick treated timber wood planks with checkered steel running plates attached to the timbers in each wheel path. The railing across the main span and approaches consists of two horizontal lines of steel angle irons, which are supported by vertical steel angle irons spaced approximately 5 feet apart. There is no crash-tested traffic railing on the bridge.

The operator's house is located on the east bank of the waterway, south of Bobtown Bridge Road. The house, which is a simple box-like structure with modern siding and sliding windows, is supported on its own foundation and is not connected to the bridge.

When the bridge is opened, a timber fender system provides approximately 49 feet of horizontal navigation clearance through the channel. Fishing boats are the main types of vessels navigating on the waterway. The bridge operator stated that the number of bridge openings in the non-shrimping season is in the range of 12-15 openings per month. During the shrimping season between May and August, the bridge is opened daily, and sometimes several times per day. The bridge is manned with an operator at all times.

In addition to the routine LADOTD inspection of this bridge every 24 months, Terrebonne Parish performs bridge inspections every 24 months in the years between LADOTD inspections.

### **C. History and significance**

The Bobtown Bridge, located approximately 10 miles south of Houma in Terrebonne Parish, carries Parish Road No. 283/Bobtown Bridge Road over Bayou Grand Caillou. It connects Grand Caillou Road/Louisiana Highway 57 to the east with a residential area along Shrimpers Row, a local road, to the west. The surrounding region, known for its fertile soil and marshes, sustains an economy that largely depends on the production of shrimp, crabs, fish, and oysters, and bayous such as the Grand Caillou

provide access between the Gulf of Mexico and inland residences and seafood markets.<sup>1</sup> Because of the commercial fishing industry, many bridges throughout the parish are movable to accommodate frequent boat traffic at certain times of the year. The Bobtown Bridge, a cable-stayed truss swing span, was constructed for this purpose in 1960.

The Louisiana Department of Highway's annual report in 1960 notes one bridge in Terrebonne Parish completed at the cost of \$6,512; this is likely the Bobtown Bridge.<sup>2</sup> It was constructed during what was still a postwar boom period for infrastructure in the state. Though swing bridges were relatively common throughout Louisiana, their population was diminishing in the mid-twentieth century because of the challenges posed by the mid-channel pivot pier, which obstructs the waterway. The Bobtown Bridge is, accordingly, a relatively late example of the swing span. This bridge is operated via a rope and pulley system that was originally manipulated by hand and is now powered with a motorized winch. While the Louisiana Department of Highways developed several standard plans for swing-span bridges between 1924 and 1961, research did not reveal whether this bridge follows a standard state plan.<sup>3</sup>

The Bobtown Bridge crosses the bayou between Grand Caillou Road, a main north-south artery in Terrebonne Parish, and Shrimpers Row, which runs north-south along the west side of the waterway. The next closest crossing is the Combon Bridge, a modern vertical lift span that stands 3 miles to the south. The Bobtown Bridge provides needed access to homes and churches west of Bayou Grand Caillou with an ADT of 400 vehicles. Its name reflects the history of development in the surrounding area, which is locally known as Bobtown. Bobtown is named for Robert Celestin, an African-American man who purchased and settled on the land in 1898. It grew into a small community with a Baptist church, store, barbershop, and two taverns, and was one of a number of all-black towns established throughout the United States in the late nineteenth and early twentieth centuries. Though Celestin died in 1952, the community remained in place, and as of 1997 consisted of approximately 25 homes on both sides of Grand Caillou Road. Bobtown Circle and the Celestin family Cemetery are located 0.2 of a mile east of the Bobtown Bridge.<sup>4</sup>

The Bobtown Bridge is eligible for listing in the National Register under *Criterion C: Engineering*. Its significance is demonstrated by the presence of distinctive engineering and design features of a cable-stayed swing bridge. These features include a truss swing span, center-bearing turning mechanism, and tower structure above the pivot pier with supporting cables. While a strengthening member has been welded to the top chord of both truss sections, resulting in a minor loss of integrity, the bridge continues to convey significant design elements of the cable-stayed swing type.

---

<sup>1</sup> History of Houma – Terrebonne,” *Terrebonne Parish Consolidated Government*, 2016, <http://www.tpcg.org/index.php?f=parish>.

<sup>2</sup> Financial and Statistical Report,” prepared for the State of Louisiana Department of Highways (June 30, 1960), 37.

<sup>3</sup> Mead & Hunt, “Historic Context for Louisiana Historic Bridge Inventory,” prepared for the Louisiana Department of Transportation and Development, November 2012, 66.

<sup>4</sup> Roland Charles, “Bobtown: The Legacy of Robert Celestin,” *The New Crisis* 104 no. 2 (October 1997): 47-49.

## D. Character-defining features

Character-defining features are prominent or distinctive aspects, qualities, or characteristics of a historic property that contribute significantly to its physical character. Features may include materials, engineering design, and structural and decorative details. Elements of the bridge that are not identified as character-defining features may be historic fabric. Historic fabric is material in a bridge that was part of original construction. It is important to consider both character-defining features and the bridge's historic fabric when planning any work.

The Bobtown Bridge has one character-defining feature: its cable-stayed truss swing span (described below). Other elements that represent historic fabric but are not considered to be character-defining are the swing span's I-beam floor system and simple handrail, approach spans to the west of the main truss, substructure elements, and timber platform for the pulley system. The operator's house exhibits many modern features and is not part of the historic fabric of the bridge. Similarly, the timber deck includes replacement members and therefore is not considered historic fabric.

The following item is the character-defining feature of this bridge:

### Feature 1: Design and construction of a truss swing span

This feature includes the main 128-foot-long, cable-stayed, truss swing span, comprised of two truss sections. It also encompasses the bridge's turning mechanism, which consists of a metal roller-and-track system. Finally, it includes the center tower and the round steel rods that support the trusses when the bridge is in the open position. Two strengthening members added to the top chords of the trusses in 2001 are not character-defining.



*Character-defining Feature Photo 1: Design and construction of a truss swing span. The steel trusses support vehicular loads when it is in the closed position; the stay cables and the top horizontal members at the tower support the truss span when in the open position.*



*Character-defining Feature Photo 2: Design and construction of center-bearing turning mechanism. This roller-and-track system guides the motion of the bridge when it opens and closes.*



*Character-defining Feature Photo 3: Design and construction of a tower structure with cables above the central pivot pier. The cables, along with the top horizontal members added in 2001, support the weight of the bridge when it is in the open position.*

The following images illustrate other bridge features that are of historic fabric, meaning they are part of original construction but are not considered to be character-defining features:



*Historic Fabric Photo 1: Steel I-beam floor system on the main swing span.*



*Historic Fabric Photo 2: Simple metal railings on the main swing span.*





*Historic Fabric Photo 3: Approach spans to the west of the main swing span.*



*Historic Fabric Photo 4: Timber platform supporting the pulley system.*

**THIS PAGE INTENTIONALLY LEFT BLANK**

## 4. Engineering Data

### A. Existing conditions

#### (1) Structural observations

The bridge is in fair condition overall and appears to adequately serve its purpose of carrying vehicular traffic over the waterway, with the ability to open to allow water navigation traffic to pass through the bridge when open. There are no major structural deficiencies for this bridge, but there are several minor deficiencies as described below. The operation of the bridge is good, as observed in two opening-closing cycles during the field visit, and the machinery and electrical systems are adequately maintained.

The bridge is classified as fracture critical for two reasons. First, the cable-stayed swing span is a longitudinal, steel, two-truss system with transverse floorbeams providing the primary structural framing and support. Second, the steel floorbeams provide primary support of the floor system. The latest bridge inspection report noted that the fracture critical members were visually inspected, and that no defects were found.

The bridge is load (weight) posted at 10 tons (10T), with signs indicating this at each end of the bridge.

#### *Approach spans*

The superstructure and substructure of the approach spans are in fair condition. The timber deck planks are in fair condition, as are the steel running plates. Approximately three timber planks have minor checking and splits in some locations. During the field visit, staff from Terrebonne Parish stated that they replace timber planks as the conditions warrant. The steel I-beams are in fair condition, with the paint system beginning to fail throughout.

The timber pile bents are in poor condition. The timber piles have been jacketed with circular steel plates, from the bottom of the timber pile caps to approximately the water line. These steel jackets have moderate paint failure and corrosion, with very minor section loss. The timber pilings have moderate splits and decay.

#### *Cable-stayed swing span*

The superstructure of the swing span is in good condition. The condition of the paint is good on the swing span trusses. There are a total of 12 stay cables, which are in good condition. All turnbuckles in the cables have minor corrosion, and the turnbuckles appear to be adequately tightened. There is minor corrosion and rust at the attachments of the cables to the center tower. The steel floorbeams and steel I-beams are in fair condition, with the paint system beginning to fail throughout.

The timber deck planks are in fair condition, as are the steel running plates. Approximately six timber planks have minor checking and splits in some locations. Staff from Terrebonne Parish stated that, as with the approach spans, they replace timber planks on the swing span as conditions warrant.

The timber pivot pier, which comprises the substructure of the span, is in fair condition. Approximately eight of the timbers have minor checking and splitting. The timber piles are in fair condition with minor splits and decay.

The operating system for the swing span is in good condition. The rollers and metal guide track on the central pivot pier are in good condition, and appear to be adequately lubricated and maintained. The motorized winch in the operator's house is new, replacing a hand-operated winch several years ago. The rope used to open the bridge is new and in excellent condition. The rope and pulley system is in satisfactory condition, as is the timber platform and supports for this system.

## **(2) Non-structural observations**

The traffic signals and traffic gates at each end of the bridge are functioning properly. When the bridge is open, traffic backs up from the bridge on Shrimpers Row to the west and to Grand Caillou Road/Louisiana Highway 57 to the east. When the bridge is closed, all vehicles backed up from one direction cross the bridge on its single lane; then after traffic clears, all traffic from the other direction crosses the bridge. As observed, motorists are familiar with using the single lane of traffic on this bridge

The operator's house is in good condition and well maintained, both inside and outside. As mentioned previously, the winch is new. Controls for operating the traffic signals and gates are satisfactory and are in good working condition. The steps from the operator's house and roadway down to the timber platform are damaged and pose a tripping or falling hazard, and need to be repaired. As of August 2016 Terrebonne Parish staff had this repair work scheduled.

The timber fender system is in fair condition. Approximately six timber walers and piles are weathered with some minor decay. For the most part, however, the fender system has been maintained to provide its function of protecting the bridge from impact loading from river navigation traffic. Lack of any impact damage to the fender system indicates that it provides for sufficient clear horizontal opening for navigation traffic.

## **(3) Serviceability observations**

The latest bridge inspection report indicates that ADT across the bridge is about 400 vehicles. This classifies the bridge as a low-volume local road, and according to the American Association of State Highway and Transportation Officials (AASHTO), does not need to conform to current roadway design criteria for geometrics and other design features. As a one-lane bridge the bridge appears to adequately handle the vehicular traffic volume. The posted speed limit across

the bridge is 5 miles per hour (mph). Pedestrians and bicyclists also use the traffic lane of this bridge to cross the Bayou Grand Caillou because there is no sidewalk.

There are no guardrails at the approaches to the bridge, and none are required. The railing across the bridge, as described previously, is not an impact crash-tested railing, but provides protection for pedestrians who cross the bridge. This railing is in good condition.

The approach roadways at each end of the bridge are approximately 15 feet long and are in satisfactory condition. Maintenance work consisting of patching the road surface has recently been performed on the pavement of the roadway at each end of the bridge.

This bridge is manned at all times.

**B. Sources of information**

<b>Plans available:</b>	Yes, available at the Terrebonne Parish Public Works Office (2001 rehabilitation plans and specifications only)
<b>Inspection report date:</b>	June 18, 2015
<b>Fracture critical report date:</b>	(included as part of routine inspection)
<b>Underwater inspection report:</b>	June 23, 2010
<b>Date of site visit:</b>	February 2, 2016



*Condition Photo 1: East approach roadway to bridge.*



*Condition Photo 2: Center pivot mechanism and pivot pier.*



*Condition Photo 3: Rope and pulley system on a timber platform, which guides the bridge as it opens and closes. Inset: Motorized winch inside the operator's house.*



*Condition Photo 4: Deck (steel running plates and timber planks) on swing span.*



*Condition Photo 5: Looking across the bridge to the west intersection with Shrimpers Row.*



*Condition Photo 6: Swing span deck cross section, shown while the bridge is opening.*





*Condition Photo 7: Timber fender system.*



*Condition Photo 8: West approach span superstructure and substructure. Note deteriorated condition of timber piles and metal circular jackets for pile splices.*



Condition Photo 9: West approach to the bridge. Note traffic gates and signals and signage.



Condition Photo 10: Profile of swing span. Horizontal top chord members on each truss are new from 2001 rehabilitation.



*Condition Photo 11: Close-up of welded connection of horizontal member from 2001 rehabilitation.*

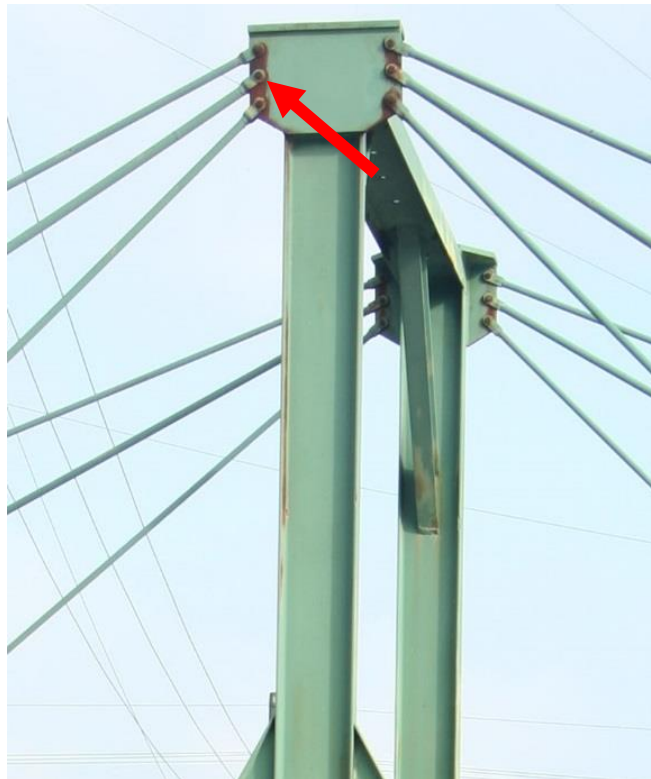

*Condition Photo 12: Condition of stay-cable attachments at top of tower in middle of swing span.*



*Condition Photo 13: Condition of timber stairway and gravel path to access timber plank platform for the ropes and pulleys of the bridge operating system.*



*Condition Photo 14: Operator's house exterior condition.*

## 5. Recommendations

This Preservation Priority Bridge should remain in use and can meet current and projected transportation needs for the next 20 years or more. Maintenance and rehabilitation activities should be completed in a manner consistent with the long-term preservation of this historic bridge. The Statewide Historic Bridge Plan provides additional guidance and approaches to completing maintenance and rehabilitation activities that adhere to the Secretary's Standards. Work should be conducted under the supervision of a qualified professional historian, as defined in the PA. The bridge engineer, or the bridge engineer's supervising engineer, should have demonstrated expertise in historic bridge projects and must have completed the LADOTD's historic bridge training. When developing plans and specifications for a project, the bridge engineer should follow the recommendations below.

Under the terms agreed upon in the PA, the bridge owner may undertake certain activities that are considered to be best practices without additional consultation or public notification. These activities are documented in Attachment 5 of the PA and are limited to the activities specifically noted. All recommended preventative maintenance and rehabilitation activities for this bridge are included in Attachment 5 and are not expected to alter the character-defining features or historic fabric of the bridge. Some cyclical or condition-based maintenance items are noted below under Rehabilitation because they are expected to be completed as part of an overall rehabilitation project for this bridge. These activities may need to be completed as conditions dictate to promote long-term preservation of this historic bridge. Recommendations within this Plan should be reviewed in 10 years following completion of the Plan to identify any needed updates or revisions.

The opinions of probable costs provided below are in 2016 dollars. The costs were developed without benefit of preliminary rehabilitation plans and are based on the above identified tasks using engineering judgment and/or gross estimates of quantities and historic unit prices and are intended to provide a programming level of estimated costs. Refinement of the probable costs is recommended once preliminary plans have been developed. The estimated preservation costs include a 10 percent contingency and 7 percent mobilization allowance of the preservation activities, excluding soft costs. Actual costs may vary significantly from those opinions of cost provided herein. Engineering design, historical consultation, and construction administration costs are not included as these may be provided by the owner or consultants.

### A. Preventative maintenance

The following are recommendations for cyclical maintenance, many of which are already routinely performed.

1. Clean and lubricate the steel sliding plates on the timber supports at each end of the swing span. The cost for this maintenance is not included in this estimate. It is recommended that this activity be performed regularly after a high water event, as it is understood is currently being done by Terrebonne Parish Public Works staff.

2. Clean and lubricate the center pivot mechanism (wheels and guide traffic) regularly to maintain good condition. Because this maintenance is routinely done, its cost is not included in this estimate.
3. Check condition of rope and pulley system regularly to maintain good condition, and replace pulleys and/or ropes as necessary. Because this maintenance is routinely done, its cost is not included in this estimate.
4. Check condition of the timber planks for the roadway surface on approach and main spans quarterly, and replace timber planks as necessary. Tighten the steel running plates as necessary. Because this maintenance is routinely done, its cost is not included in this estimate.

There is one condition-based maintenance activity recommended. As of August 2016 Terrebonne Parish staff had this work scheduled.

1. Repair the wooden stairs leading down from the operator's house and roadway on the east side of the bridge to the timber platform and support system for the pulleys and cables.

<b>Bridge Recall No. 200868</b>		Date:	3/23/2016	
<b>Bobtown Bridge over Grand Caillou Bayou</b>				
<b>Opinion of Probable Costs</b>				
<b>Maintenance</b>				
Item	Quantity	Unit	Unit Cost	Total
Repair wooden stairs at east end of bridge down to walkway	1	LS	\$500	\$500
Item Subtotal				\$500
Contingency			10.00%	\$50
Mobilization			7.00%	\$39
<b>TOTAL</b>				<b>\$589</b>
			<b>Round to:</b>	<b>\$600</b>

**B. Rehabilitation**

The following are recommendations for rehabilitation. The activities listed should be performed when necessary (estimated to be within the next two years).

1. Clean and lubricate the connections of the round steel rods to the top of the towers and to the truss spans. This activity should be performed when necessary (estimated to be within the next two years).
2. Clean, tighten, and lubricate turnbuckles for round steel rods. This activity should be performed when necessary (estimated to be within the next two years).

3. Remove and replace deteriorated timber piles for the westerly approach spans. It is estimated that 12 timber piles need to be replaced with new treated timber piles. An option to replacing the piles is to remove the upper deteriorated sections of the piles, and splice with new treated timbers and circular steel plates of such diameter to provide support for the spliced piles. This activity should be performed when necessary (estimated to be within the next year).

Bridge Recall No. 200868			Date:	3/23/2016	
Bobtown Bridge					
Opinion of Probable Costs					
Rehabilitation					
<b>Item</b>	<b>Quantity</b>	<b>Unit</b>	<b>Unit Cost</b>	<b>Total</b>	
Clean and lubricate connections of cable-stay rods to tower & trusses	12	EA	\$200	\$2,400	
Clean, tighten and lubricate all turnbuckles for cable stay rods	12	EA	\$100	\$1,200	
Remove and replace, or splice new piles to top of, deteriorated timber piles for west spans	12	EA	\$3,000	\$36,000	
Item Subtotal				\$39,600	
Contingency			10.00%	\$3,960	
Mobilization			7.00%	\$3,049	
<b>TOTAL</b>				<b>\$46,609</b>	
			Round to:	<b>\$47,000</b>	

**C. Identification of any anticipated design exceptions**

No design exceptions recommended, especially because this bridge is on a low-volume local road.

**THIS PAGE INTENTIONALLY LEFT BLANK**



**Appendix A. Historic Inventory Form**

**THIS PAGE INTENTIONALLY LEFT BLANK**

# Louisiana Historic Bridge Inventory

Recall Number: 200868

Structure Number: P5529283904221

SHPO Number: 55-01180

Bridge Name: TERREBONNE PH RD NO 0283

## Location Data:

District: 02

Parish: Terrebonne

Feature Crossed: GRAND CAILLOU BAYOU

Facility Carried: LOCAL ROAD

Location: 0005 LOG MI FROM IN

City, Village or Town (if applicable):

Status: Open

Bridge Owner: Parish Highway Agency

Latitude: 29.471667

Longitude: -90.703333

---

## Structural Data:

Bridge Type: Steel Low Truss Swing Span

Year Built: 1960

Main Span Configuration (if applicable): Cable-stayed swing span

Maximum Span Length (feet): 64

Number of Spans: 1

Overall Structure Length (feet): 158

Approach Span Type (if applicable): Steel stringer/multi-beam or girder

Posted Load:

Current ADT: 000400

---

## Design and Construction Data:

Engineer or Builder:

Unknown

Bridge Plaque:

None

---

## National Register of Historic Places Evaluation:

This cable-stayed swing bridge has significance as an important example of a movable bridge and as a subtype. Its significance is demonstrated by the presence of distinctive engineering and design features of a cable-stayed swing bridge, which is characterized by a truss swing span, center-bearing turning mechanism, pivot pier, and tower structure above the pivot pier with cables that support the bridge in open position. A strengthening member has been welded to the top chord of the trusses that results in a minor loss of integrity, but the bridge continued to convey significant design features of the cable-stayed swing bridge subtype. This bridge is eligible for listing in the National Register under Criterion C: Design/Engineering.

No evidence was found during research or data collection activities to indicate that this bridge possesses a direct and important association with historical events or trends. This bridge does not possess significance under Criterion A.

---

Within/Adjacent to Known Historic District: N/A

National Register Historic District Name: N/A

National Register Determination: Eligible

National Register Determination Date: 2013

Surveyor: Mead & Hunt, Inc.

Date Surveyed: 2013



# Louisiana Historic Bridge Inventory

Recall Number: 200868

Structure Number: P5529283904221

Bridge Name: TERREBONNE PH RD NO 0283

Parish: Terrebonne

Bridge Owner: Parish Highway Agency

Feature Crossed: GRAND CAILLOU BAYOU

Facility Carried: LOCAL ROAD

## Photographs:



**Appendix B. Select Plan Sheets**

**THIS PAGE INTENTIONALLY LEFT BLANK**

TERREBONNE PARISH CONSOLIDATED GOVERNMENT

**BOBTOWN BRIDGE REPAIRS**  
**TERREBONNE PARISH, LA**

PARISH PROJECT No. 98-BRG-11  
 CEECPROJECT No. 1485

FEBRUARY 2001



ROBERT BERGERON - PARISH PRESIDENT

TERREBONNE PARISH COUNCIL

DANIEL D. HENRY - CHAIRMAN  
 RAY B. BOUDREAUX - V. CHAIRPERSON

COUNCIL MEMBERS BY DISTRICT

- DISTRICT 1 - ALVIN TILLMAN
- DISTRICT 2 - WAYNE THIBODEAUX
- DISTRICT 3 - RAY B. BOUDREAUX
- DISTRICT 4 - CHRISTA DUPLANTIS
- DISTRICT 5 - J.B. BREAUX
- DISTRICT 6 - HAROLD LAPEYRE
- DISTRICT 7 - CLAYTON VOISIN
- DISTRICT 8 - PETER RHODES
- DISTRICT 9 - DANIEL D. HENRY

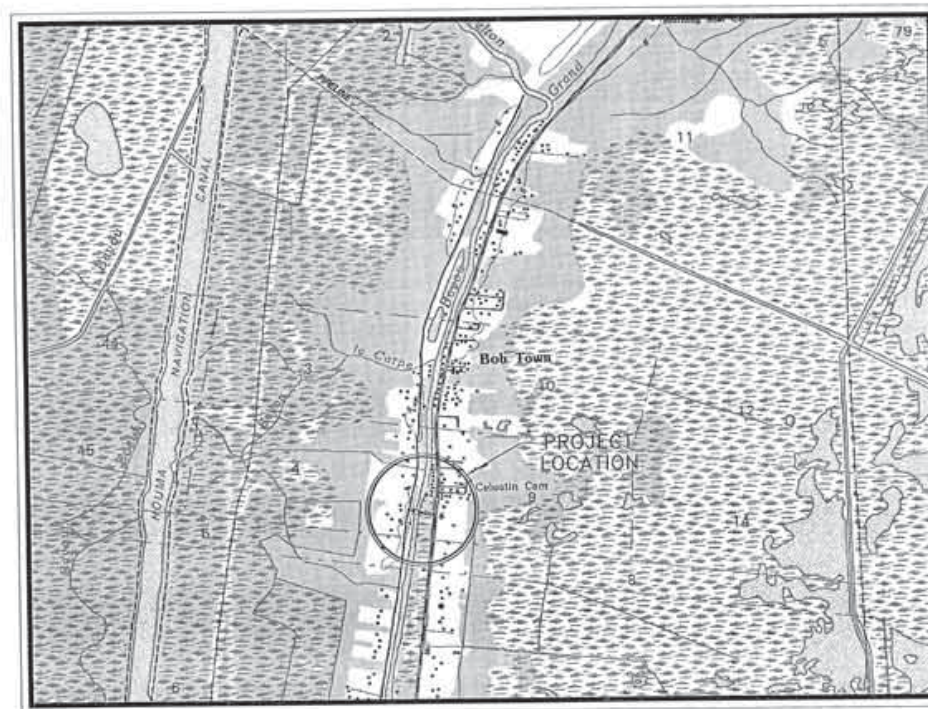

VICINITY MAP



INDEX

SHEET NO.	DESCRIPTION
1	TITLE SHEET
2	SITE PLAN
3	EXISTING BRIDGE PLAN AND ELEVATION
4	PROPOSED BRIDGE PLAN AND ELEVATION
5	BRIDGE DETAILS
6	BRIDGE APPROACH DETAILS



Approved: *William J. Mouton, Jr.*

Date: 12 Feb 2001

WILLIAM J. MOUTON Jr., Reg. Civil Engineer & Land Surveyor  
 Chief Engineer  
 Coastal Engineering &  
 Environmental Consultants, Inc.



Safety is a Part of Your Contract

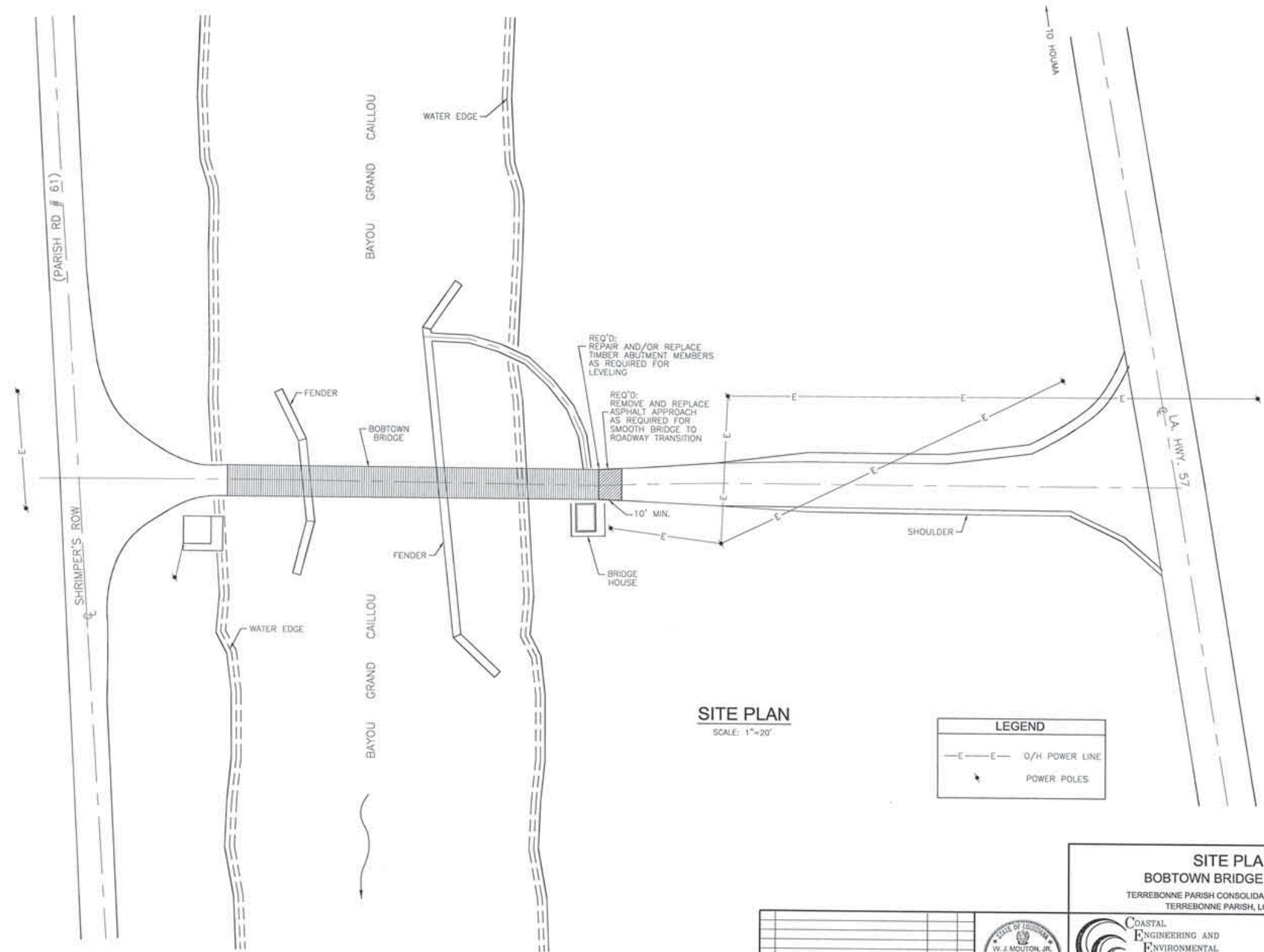

**SITE PLAN**  
SCALE: 1"=20'

LEGEND	
—E—E—	O/H POWER LINE
●	POWER POLES

**RECEIVED**  
FEB 19 2001  
ENGINEERING

**SITE PLAN**  
**BOBTOWN BRIDGE REPAIRS**  
TERREBONNE PARISH CONSOLIDATED GOVERNMENT  
TERREBONNE PARISH, LOUISIANA

NO.	REVISIONS	DATE	BY
3	GENERAL REVISIONS	01/25/01 RAC	
2	GENERAL REVISIONS	06/23/99 D.J.P.	
1	GENERAL REVISIONS	05/14/99 D.J.P.	
NO.	REVISIONS	DATE	BY



MAIN OFFICE LOCATION:  
137 ELYSIAN DRIVE  
HOUMA, LA. 70363  
WITH OFFICES IN  
WESTMO AND BATON ROUGE, LA.  
PHONE: (504) 858-3434  
FAX: (504) 858-8513

DESIGNED BY:	DRAWN BY:	CHECKED BY:	DATE:	SCALE:	PROJECT NO.:	SHEET #
R.K.	D.J.P.	D.C.S.	05/23/99	1" = 20'	1455	2 OF 6





Safety is a Part of Your Contract

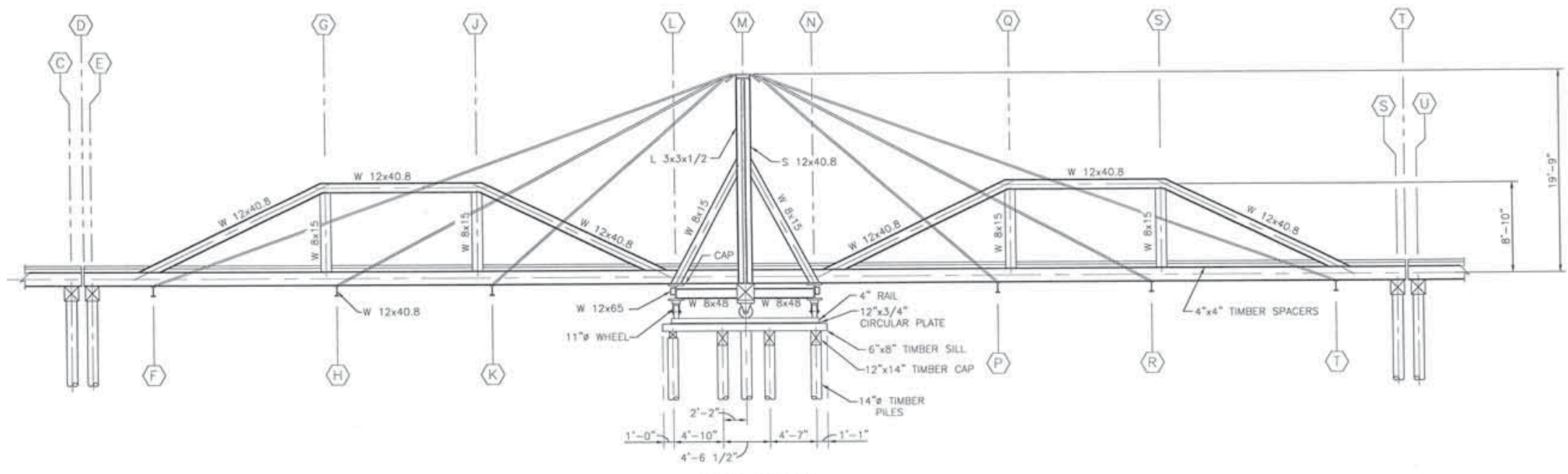

**ELEVATION**  
SCALE: 3/16"=1'-0"

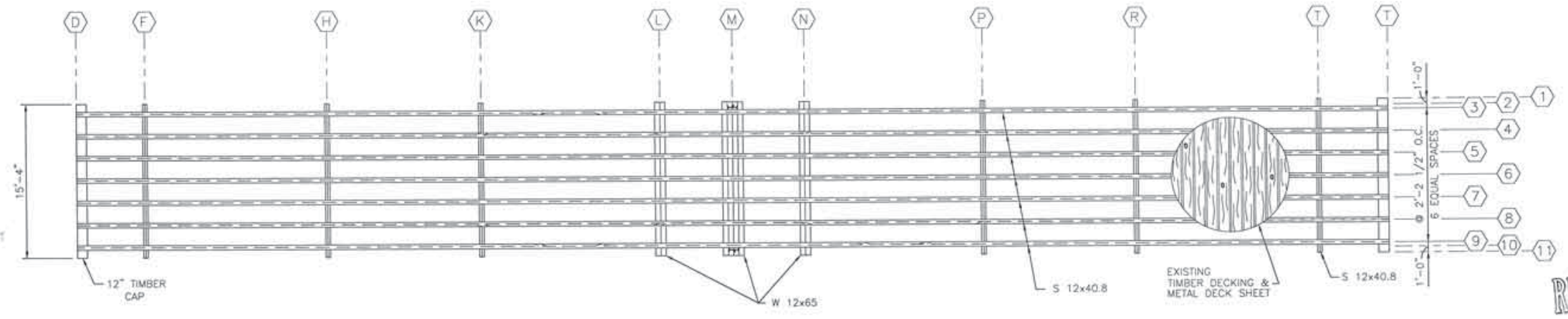

**PLAN**  
SCALE: 3/16"=1'-0"

- NOTES:**
1. CONTRACTOR TO VERIFY ALL THE DIMENSIONS AND MEMBERS IN THE FIELD.
  2. SHADED AREAS INDICATE ADDITIONS OR REPLACEMENTS.
  3. HANDRAILS AND DECK ARE NOT SHOWN FOR CLARITY.



NO.	REVISIONS	DATE	BY
3	GENERAL REVISIONS	01/20/01	K.A.C.
2	GENERAL REVISIONS	06/22/99	D.J.P.
1	GENERAL REVISIONS	06/16/99	D.J.P.
	REVISIONS		



**EXISTING BRIDGE PLAN AND ELEVATION**  
BOBTOWN BRIDGE REPAIRS  
TERREBONNE PARISH CONSOLIDATED GOVERNMENT  
TERREBONNE PARISH, LOUISIANA



MAIN OFFICE LOCATION:  
197 ELYSIAN DRIVE  
HOUMA, LA. 70363  
WITH OFFICES IN  
WESTWOOD AND BATON ROUGE, LA.  
PHONE: (504) 868-3434  
FAX: (504) 868-8513

DESIGNED BY: R.K. DRAWN BY: D.J.P. CHECKED BY: D.C.S. DATE: 06/23/99 SCALE: 3/16"=1'-0" PROJECT NO: 1485 SHEET # 3 OF 6

RECEIVED  
FEB 19 2001  
ENGINEERING

Safety is a Part of Your Contract

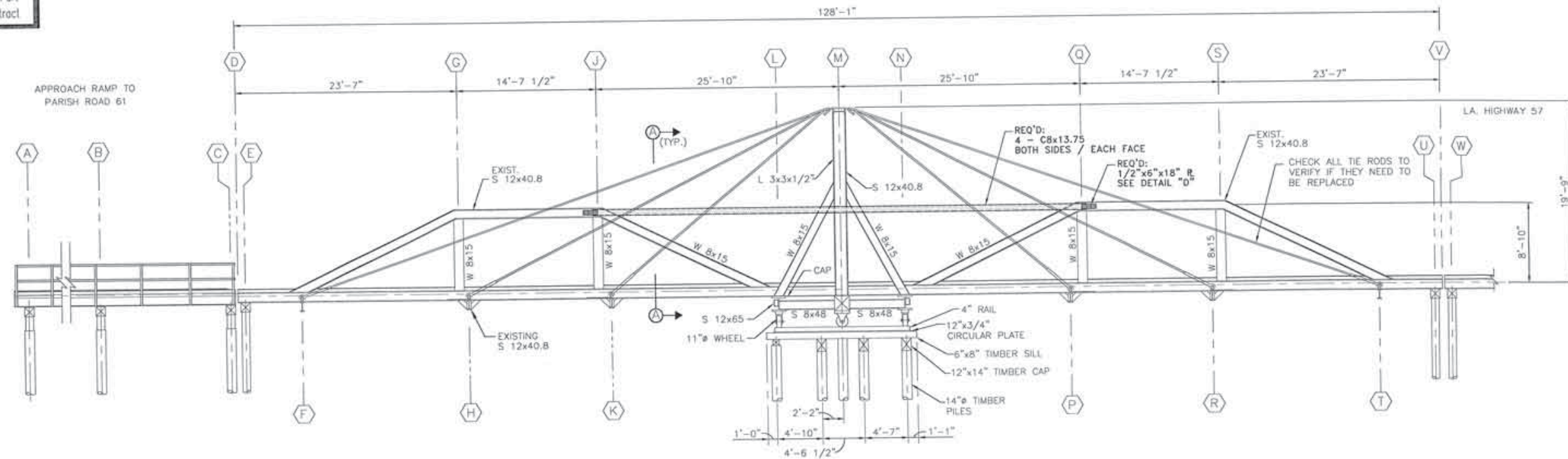

**ELEVATION**  
SCALE: 3/16"=1'-0"

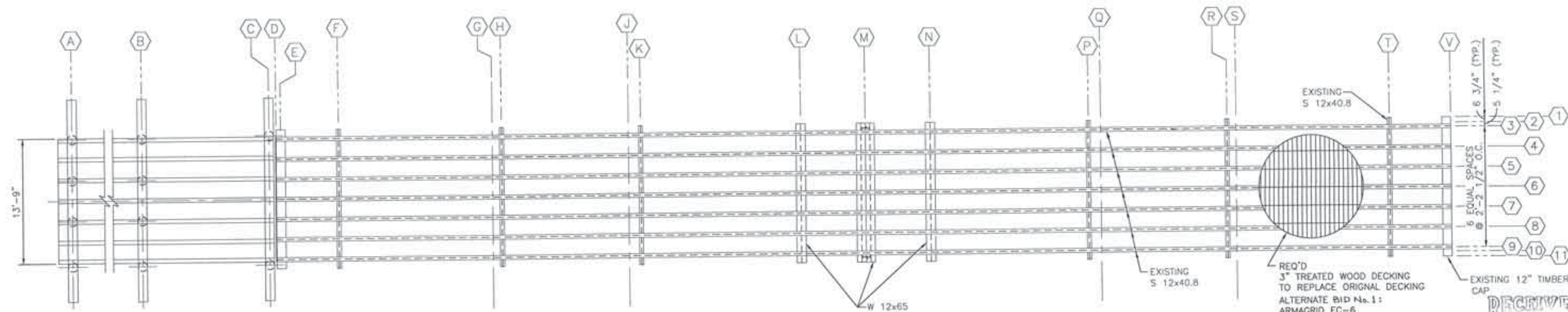

**PLAN**  
SCALE: 3/16"=1'-0"

- NOTES:**
1. CONTRACTOR TO VERIFY ALL THE DIMENSIONS AND MEMBERS IN THE FIELD.
  2. SHADED AREAS INDICATE ADDITIONS OR REPLACEMENTS.
  3. HANDRAILS AND DECK ARE NOT SHOWN FOR CLARITY.



NO.	REVISIONS	DATE	BY
6	NEW SUPPORTS	02/12/01	R.A.P.
5	GENERAL REVISIONS	01/20/01	R.A.C.
4	GENERAL REVISIONS	08/23/99	J.P.
3	GENERAL REVISIONS	08/22/99	J.P.
2	GENERAL REVISIONS	06/14/99	J.P.
1	GENERAL REVISIONS	06/11/99	J.P.

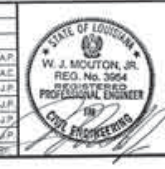

**PROPOSED BRIDGE PLAN AND ELEVATION**  
**BOBTOWN BRIDGE REPAIRS**  
TERREBONNE PARISH CONSOLIDATED GOVERNMENT  
TERREBONNE PARISH, LOUISIANA



MAIN OFFICE LOCATION:  
197 ELYSIAN DRIVE  
HOLMA, LA, 70363  
WITH OFFICES IN  
WESTMOOR AND BRUSH RIDGE, LA  
PHONE: (504) 868-5434  
FAX: (504) 868-8513

DESIGNED BY: R.X.	DRAWN BY: D.J.P.	CHECKED BY: D.C.S.	DATE: 06/23/99	SCALE: 3/16"=1'-0"	PROJECT NO: 1485	SHEET # 4 OF 6
-------------------	------------------	--------------------	----------------	--------------------	------------------	----------------

Safely is a Part of Your Contract

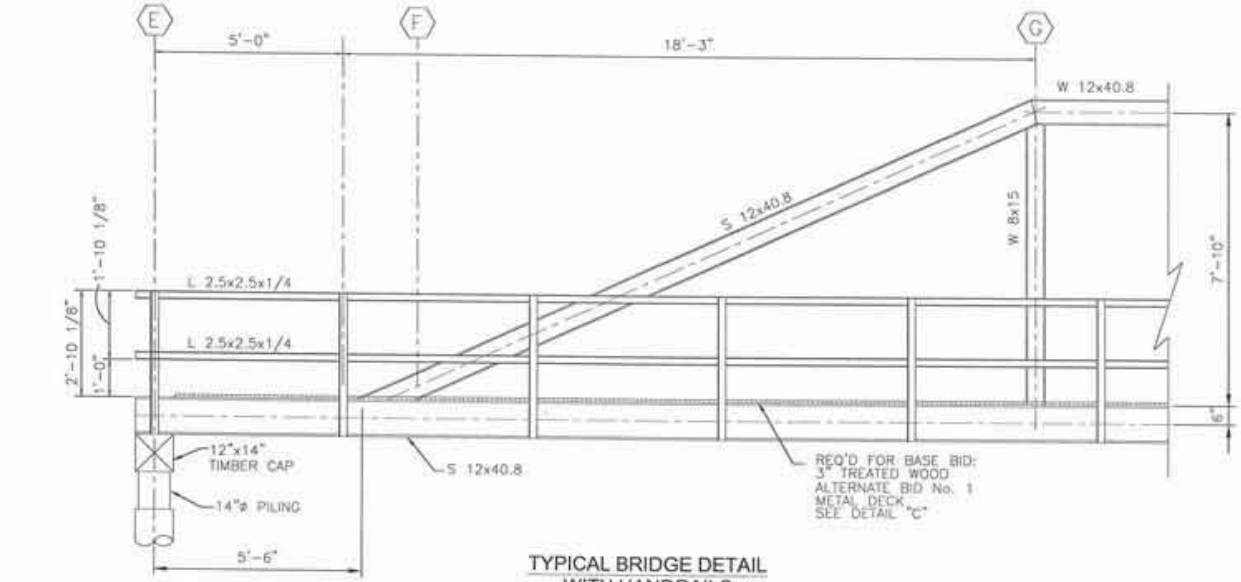

TYPICAL BRIDGE DETAIL WITH HANDRAILS  
SCALE: 1/2" = 1'-0"

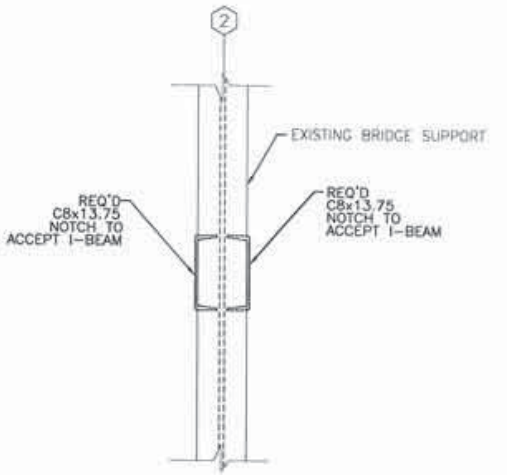

STRUCTURAL BRACING DETAIL "G"  
SCALE: N.T.S.

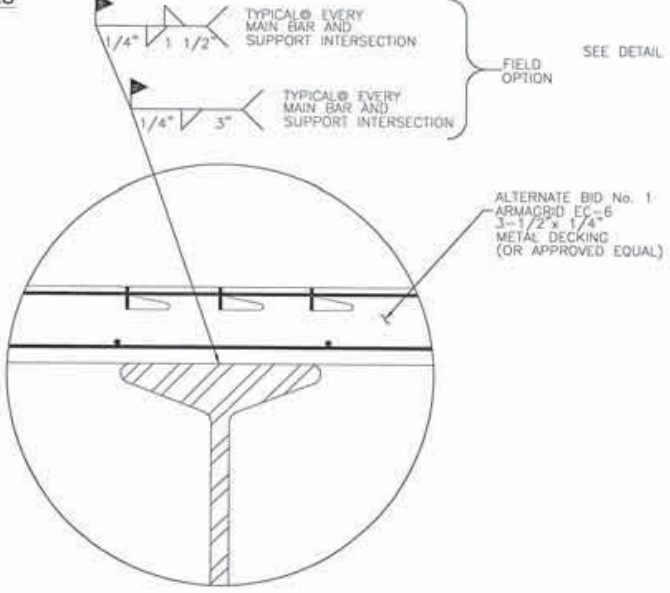

ALTERNATE BID No. 1 METAL DECKING CONNECTION DETAIL "C"  
NOT TO SCALE

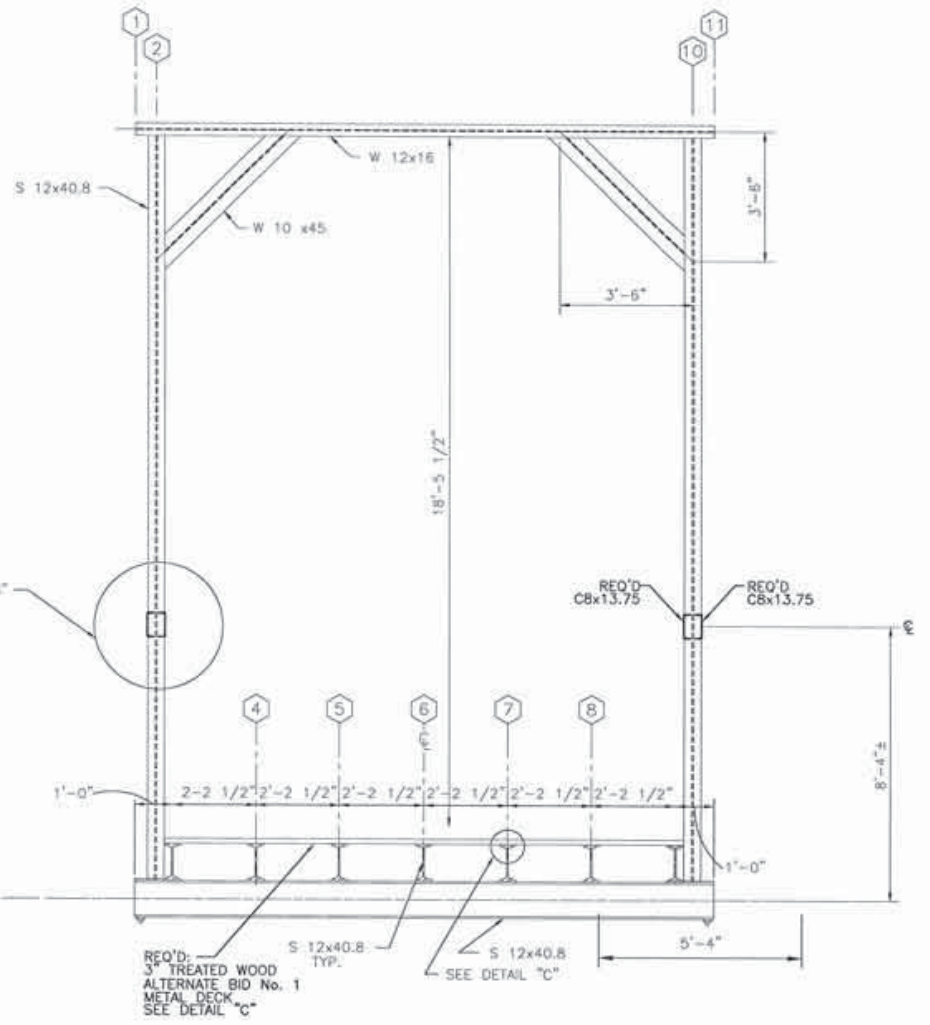

PROPOSED BRIDGE SECTION A-A  
SOME MEMBERS NOT SHOWN FOR CLARITY  
SCALE: 1/2" = 1'-0"

NOTES

1. VERIFY ALL DIMENSIONS AND MEMBERS IN THE FIELD.
2. ALL WELDING SHOULD BE ACCORDING TO AWS SPECIFICATIONS; ALL JOINTS TO BE WELDED FOR FULL CONTINUITY.
3. SHOP DRAWINGS MUST BE PROVIDED TO THE ENGINEER FOR APPROVAL PRIOR TO FABRICATION.
4. REFURBISH TURNBUCKLES AND CABLE RODS IN CONSULTATION WITH ENGINEER.
5. **BASE BID:** REPLACE THE TIMBER DECK, METAL DECK SHEETING, AND TIMBER 4" x 4" SPACERS WITH 3" TREATED WOOD DECKING.  
**ALTERNATE BID No.1:** ARMAGRID EC-6 3-1/2" x 1/4" METAL DECKING (OR APPROVED EQUAL) AND 3 1/2" x 3 1/2" SQUARE TUBING. (APPROACH ONLY)
6. ADD METAL LEVELING SHIM'S ON APPROACH, DECK AS REQ'D.
7. REMOVE AND REPLACE ASPHALT, EAST APPROACH TO BRIDGE (SEE SHEET 2)
8. REPAIR AND REPLACE TIMBER ABUTMENT MEMBERS AS REQUIRED FOR LEVELING. (SEE SHEET 2).
9. COMMERCIAL SANDBLAST AND PAINT BRIDGE AND BRIDGE APPROACH.
10. AFTER THE REPAIRS, THE BRIDGE MUST BE IN PERFECT HORIZONTAL AND VERTICAL ALIGNMENT WITH THE RAMPS.
11. INSPECT AND SUBMIT RECOMMENDATION ON THE CONDITION OF THE TRUNNION CENTER PIVOT PLATFORM FOUNDATION, RAMP SILLS AND FOUNDATION PILING, AND THE BRIDGE SKID PLATE, SILLS AND FOUNDATION PILING TO THE ENGINEERING FOR CONSULTATION.
12. INSPECT AND SUBMIT RECOMMENDATION ON THE CONDITION OF THE STRINGERS AND FLOOR BEAMS TO THE ENGINEER FOR CONSULTATION.
13. INSPECT AND SUBMIT RECOMMENDATION ON THE CONDITION OF THE TRUNNION CENTER PIVOT, TRUNNION WHEELS, BUSHINGS, AND SUPPORT BRACKETS TO THE ENGINEER FOR CONSULTATION.



NO.	REVISIONS	DATE	BY
4	NEW SUPPORTS	02/12/01 R.A.P.	
3	GENERAL REVISIONS	01/29/01 R.A.C.	
2	GENERAL REVISIONS	06/22/99 D.J.P.	
1	GENERAL REVISIONS	06/17/99 D.J.P.	
0	REVISIONS		



BRIDGE DETAILS  
BOBTOWN BRIDGE REPAIRS  
TERREBONNE PARISH CONSOLIDATED GOVERNMENT  
TERREBONNE PARISH, LOUISIANA

**COASTAL ENGINEERING AND ENVIRONMENTAL CONSULTANTS, INC.**  
Engineers - Scientists - Planners - Environmental Consultants

WITH OFFICE LOCATION:  
197 ELYSIAN DRIVE  
HOUMA, LA. 70363

WITH OFFICES IN:  
WESTWOOD AND BAYOU ROUGE, LA.  
PHONE: (504) 866-3434  
FAX: (504) 866-8513

DESIGNED BY: R.K. DRAWN BY: D.J.P. CHECKED BY: D.C.S. DATE: 06/21/99 SCALE: 1/2"=1'-0" PROJECT NO: 1485 SHEET # 5 OF 8

Safety is a Part  
of Your Contract

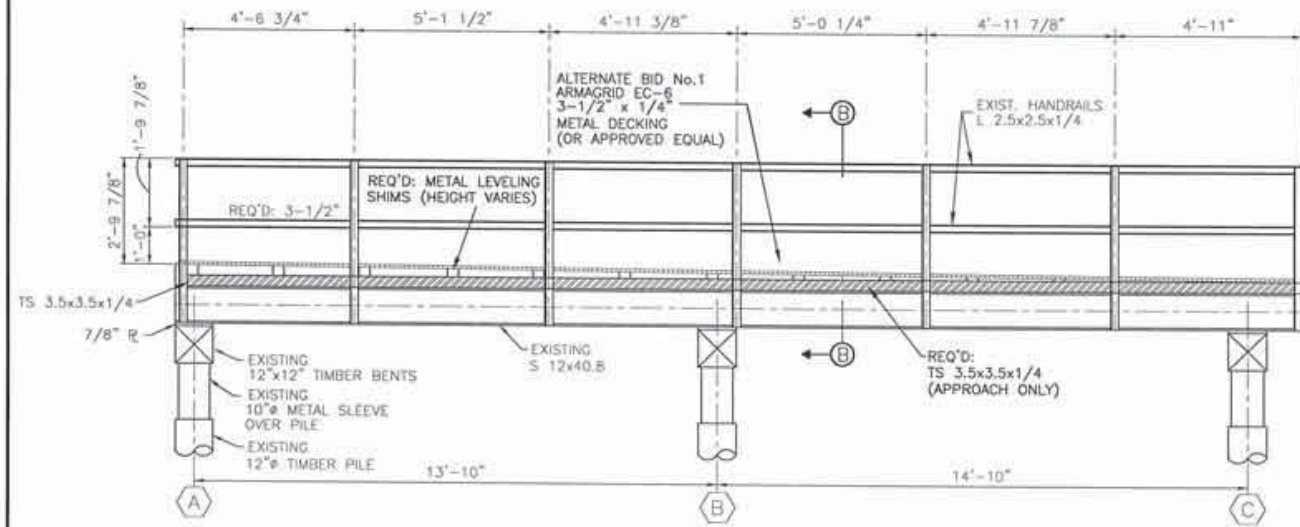

ALTERNATE BID No. 1 BRIDGE APPROACH DETAIL  
SHRIMPERS ROW (PARISH ROAD 61)  
SCALE: 1/2" = 1'-0"

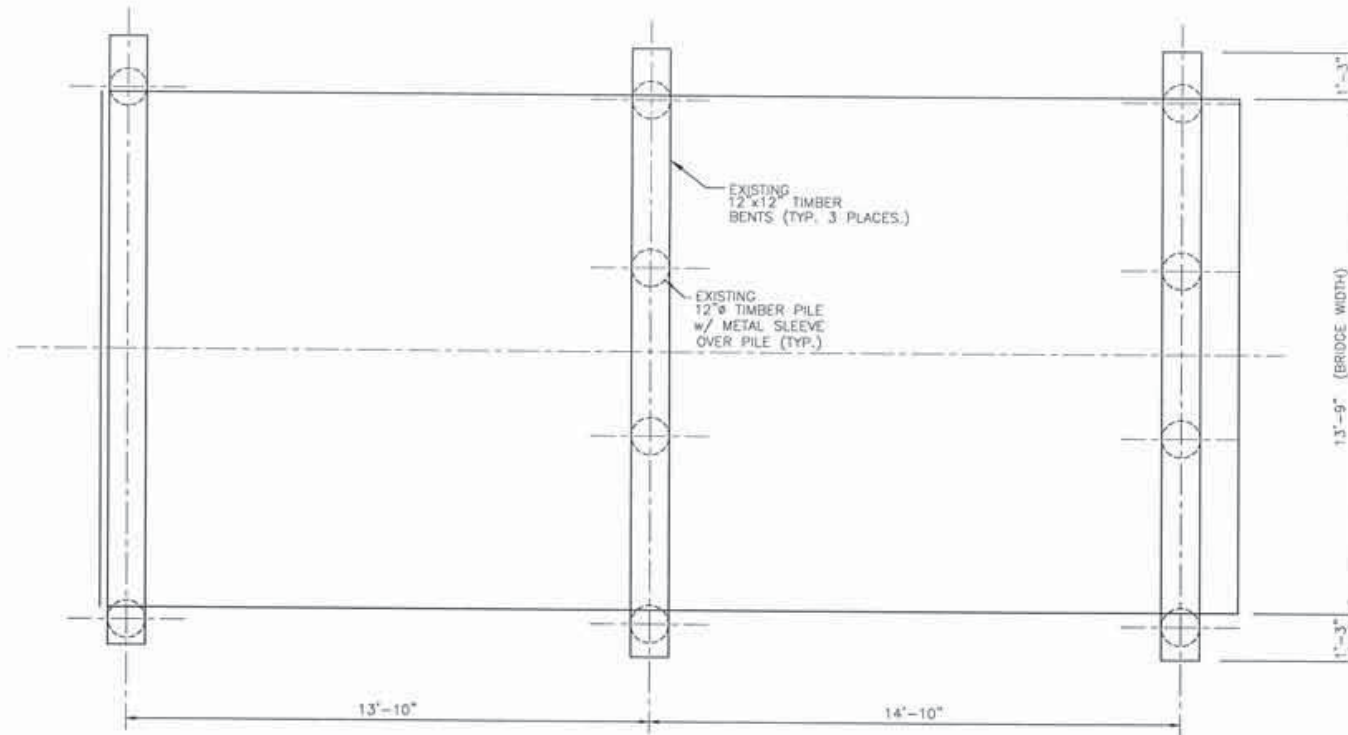

EXISTING BRIDGE APPROACH PLAN (For information purposes only)  
SCALE: 1/2" = 1'-0"

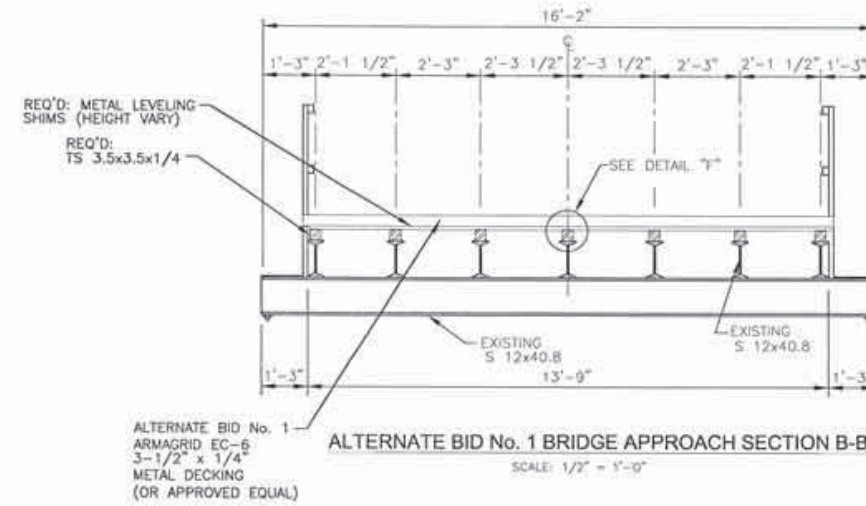

ALTERNATE BID No. 1 BRIDGE APPROACH SECTION B-B  
SCALE: 1/2" = 1'-0"

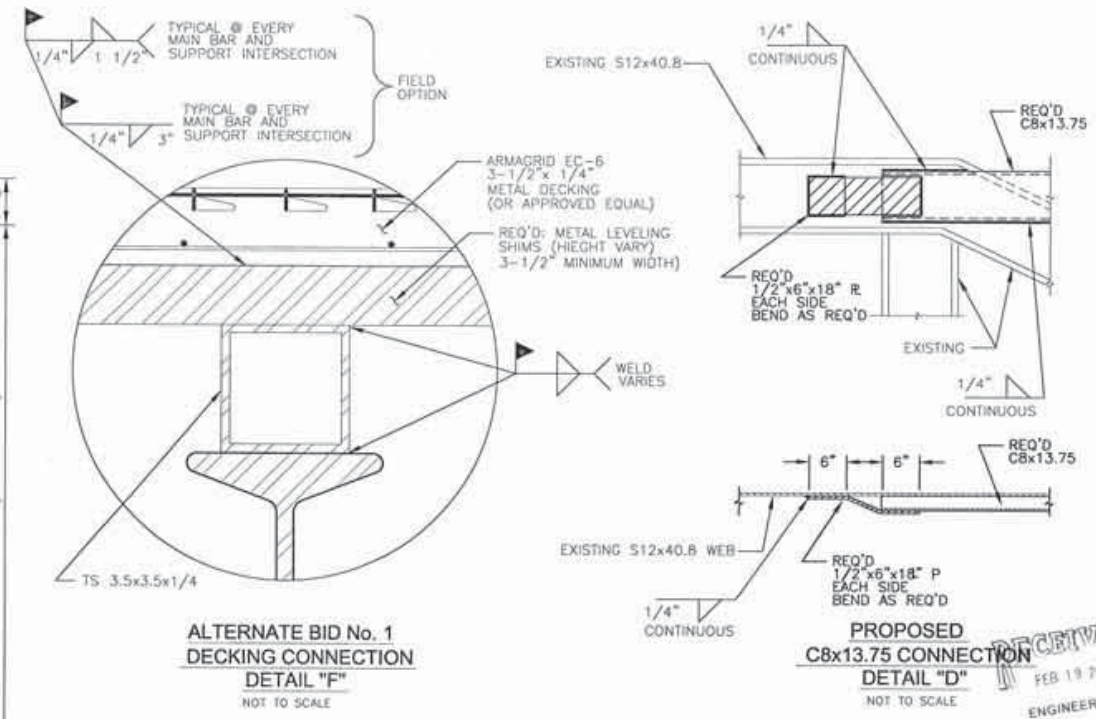

ALTERNATE BID No. 1  
DECKING CONNECTION  
DETAIL "F"  
NOT TO SCALE

PROPOSED  
C8x13.75 CONNECTION  
DETAIL "D"  
NOT TO SCALE



NO.	REVISIONS	DATE	BY
4	GENERAL REVISIONS	01/20/01	R.A.C.
3	GENERAL REVISIONS	06/24/00	J.P.
2	GENERAL REVISIONS	04/22/99	J.P.
1	GENERAL REVISIONS	03/17/99	J.P.
	REVISIONS		



**COASTAL ENGINEERING AND ENVIRONMENTAL CONSULTANTS, INC.**  
Engineers - Scientists - Planners - Environmental Consultants

MAIN OFFICE LOCATION:  
197 ELYSIAN DRIVE  
HOLMA, LA 70363  
WITH OFFICES IN  
WESTBO AND BRON ROUSE, LA  
PHONE: (504) 868-3434  
FAX: (504) 868-8513

**BRIDGE APPROACH DETAILS**  
**BOBTOWN BRIDGE REPAIRS**  
TERREBONNE PARISH CONSOLIDATED GOVERNMENT  
TERREBONNE PARISH, LOUISIANA

DESIGNED BY: R.K. DRAWN BY: D.J.P. CHECKED BY: D.C.S. DATE: 06/23/99 SCALE: 1/2"=1'-0" PROJECT NO: 1485 SHEET # 6 OF 6